

PROD		LOC	DIST	P		F		REVISIONS			
4081		DF	SO					DESCRIPTION		DATE	APPD
								H	REV & REDRAWN; 0600-5874-96	CT 11-96	CS

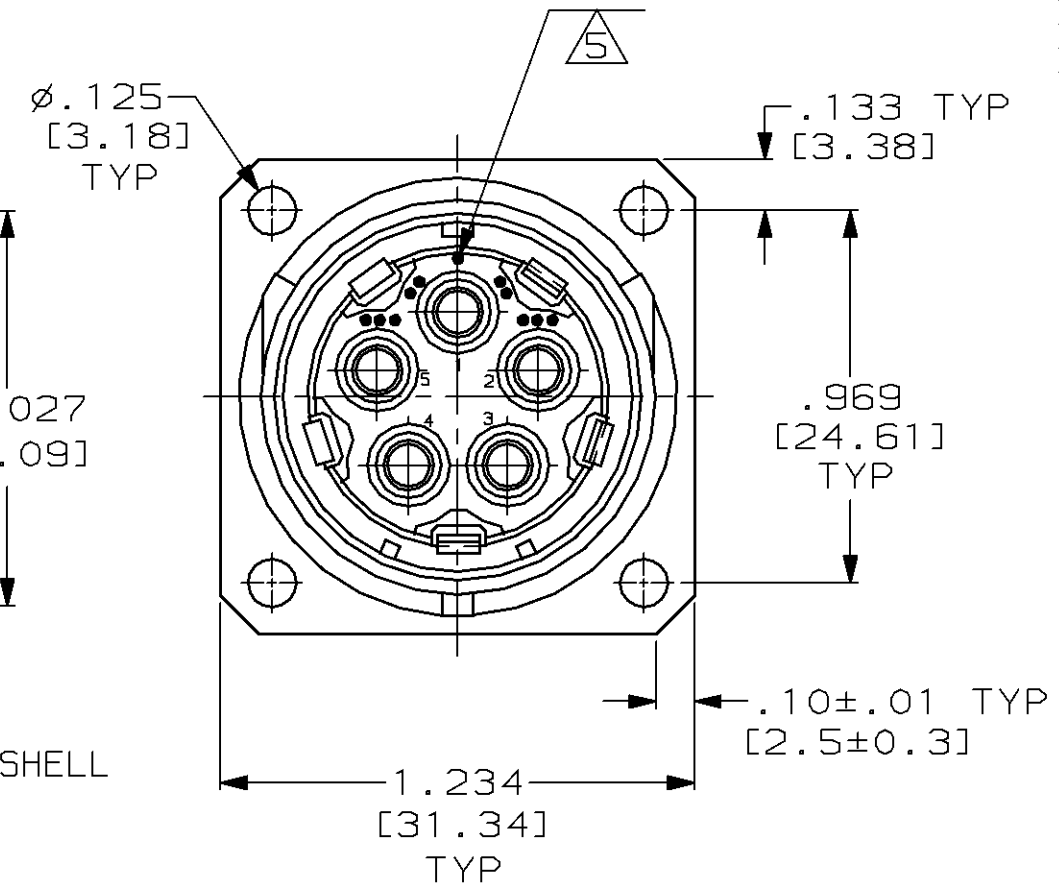
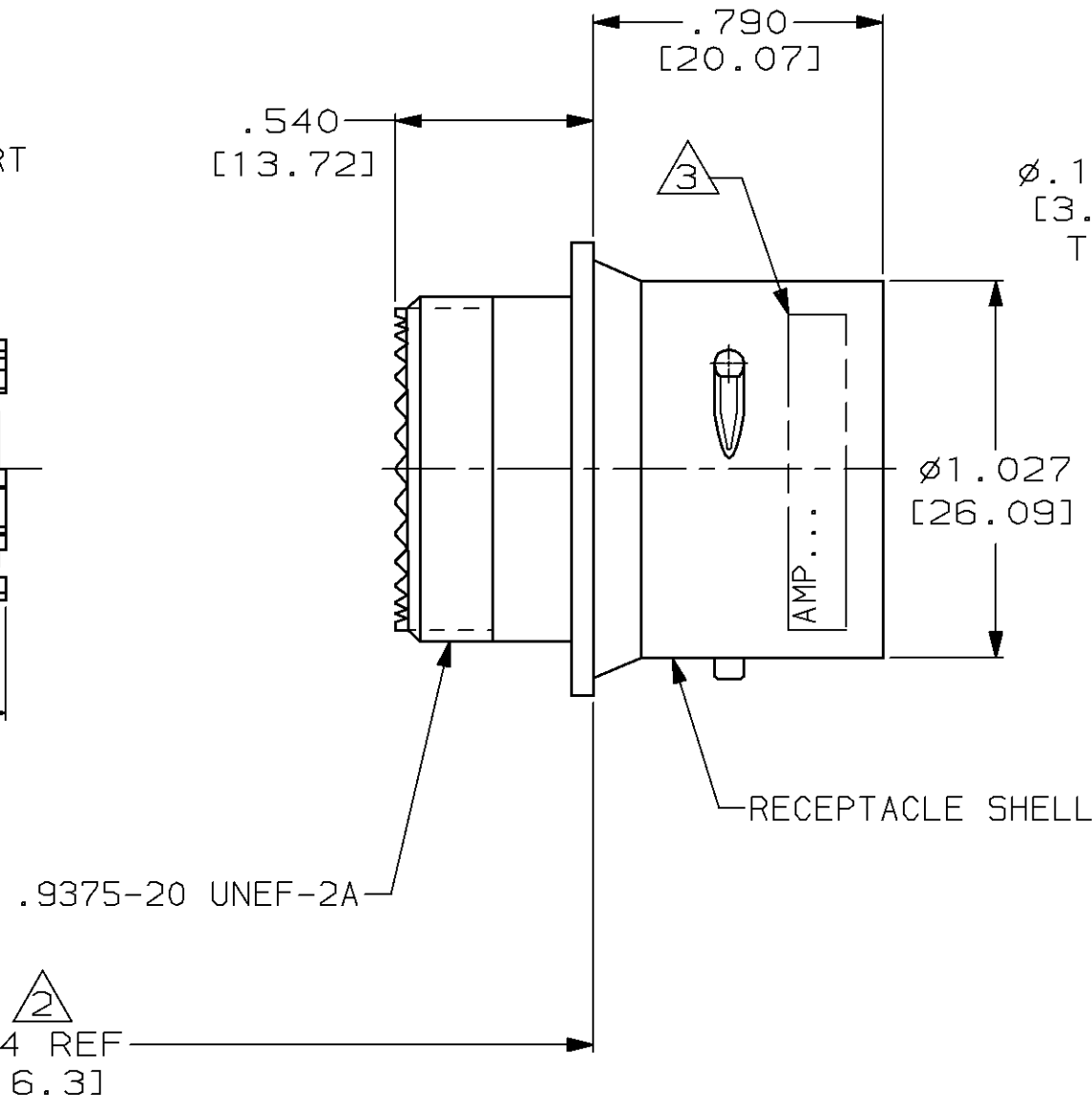
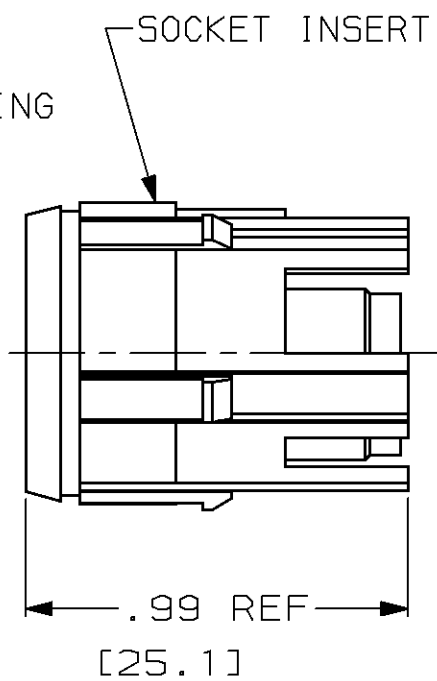
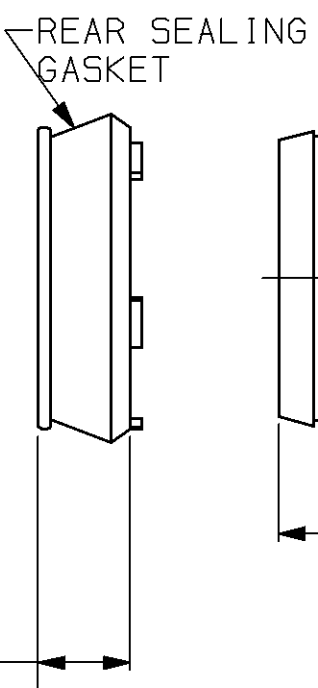
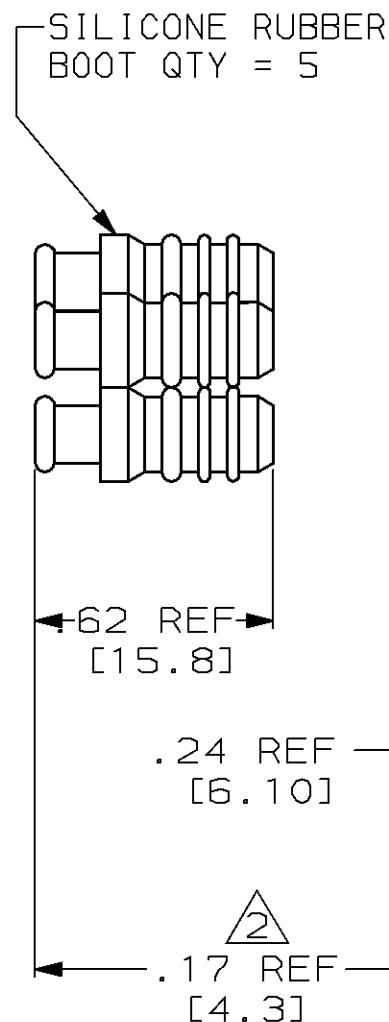
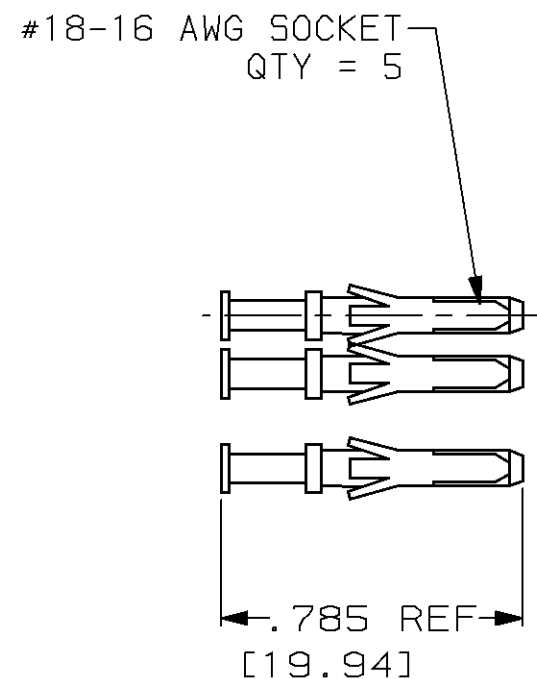

- THIS RECEPTACLE REQUIRES A SIZE 16 MIL-C-38999F BACKSHELL OR EQUIVALENT STRAIN RELIEF.
- THE INDICATED DIMENSIONS APPLY AFTER ASSEMBLY. COMPLETE OVERALL DIMENSIONS AFTER ASSEMBLY DEPEND UPON THE SPECIFIC BACKSHELL OR STRAIN RELIEF USED.
- MARKED PER MIL-STD-130 USING BLACK INK. .09 [2.3] HIGH CHARS FOR -1 ONLY. .060 [1.52] HIGH CHARS FOR ALL OTHER DASH NUMBERS. SEE TABLE FOR SPECIAL MARKING.
- TO ASSEMBLE SEE INSTRUCTION SHEET #864886-4.
- SINGLE DOT POLARIZATION SHOWN FOR REFERENCE ONLY.

(00779/AMP, 863754-4) DATE CODE	49956-848285-1B REV M	863754-4
(00779/AMP, 863754-3) DATE CODE	49956-848285-1A REV M	863754-3
(00779/AMP, 863754-2) DATE CODE	49956-848285-1 REV M	863754-2
(00779/AMP, 863754-1) DATE CODE	-	863754-1
AMP INFO		CUSTOMER INFO
MARKING		PART NO.

DO NOT SCALE PRINT. UNLESS SPECIFIED DIMENSIONS IN INCHES [mm] TOLERANCES ON : 2 PLC DEC ± .02 [0.5] 3 PLC DEC ± .010 [0.25] ANGLES ± -	DR 11-19-96 C.C. THOMAS	<b>AMP</b> AMP Incorporated Harrisburg, PA 17105-3608	
MATERIAL -	CHK 11-26-96 C.SHELLY		
FINISH -	APPD 11-26-96 C.SHELLY	NAME RCPT KIT, 5 POSN., LGH	
	RLSE 11-26-96 C.C. THOMAS	SIZE C	CAGE CODE 00779
	PRODUCT SPEC -	DRAWING NO	G=863754
	APPLICATION SPEC -	SCALE 2:1	SHEET 1 OF 1
	WEIGHT -		

THIS DRAWING IS A CONTROLLED DOCUMENT FOR AMP INCORPORATED. IT IS SUBJECT TO CHANGE AND THE CONTROLLING ENGINEERING ORGANIZATION SHOULD BE CONTACTED FOR THE LATEST REVISION.